

Multicasting in Frequency Selective Channels with One-bit DACs

Sidharth Kumar, and Robert W. Heath Jr. Fellow, IEEE

Abstract—In this paper, we design a beamforming method for physical layer multicasting, where the base station is equipped with one-bit Digital-to-analog converters (DAC). To overcome frequency selectivity of the wideband channel, the base station employs orthogonal frequency division multiplexing (OFDM) transmission. We design the frequency domain beamforming vector by equalizing the channel among all users. Numerical simulations show that the proposed beamforming approach provides 11 dB on average signal-to-quantization-plus-noise ratio (SQNR) gain compared to the baseline equal combining beamforming approach.

Index Terms—Mm-Wave, multicasting, one-bit DAC, beamforming, MIMO-OFDM.

I. INTRODUCTION

Transmitting the same data to multiple users through wireless multicasting is valuable for satisfying the high data rate requirements of 5G and beyond cellular networks. With proper beamforming, the transmitter can improve the rate of worst user in the multicast system thus improving overall system performance. Previous work on multicast precoding include (i) transmit beamforming optimization to maximize quality of service or minimum signal-to-noise ratios at receivers [1], [2], (ii) theoretical capacity limit calculations [3], [4], (iii) trade-offs between throughput and delay considerations [5], or (iv) multicast for multiple input multiple output (MIMO) OFDM system [6]. The work in [1] concludes that multicast problem is NP-hard for a single cell single carrier system, whereas work in [2], extrapolates that work for a multi-cell scenario. Information theoretic limit of multicast channel under Rayleigh fading was evaluated in [3], building over that [4] investigated capacity of uncorrelated Rayleigh distribution. The work in [5] looked at the wireless multicast problem from the network layer perspective and derived linear scaling laws for throughput and delay with increase in number of users. To optimize minimum rate for a wideband system, an iterative algorithm for MIMO-OFDM system is presented in [6] assuming mutually independent transmitter signal vector.

MmWave spectrum is lucrative for increasing data rates just by virtue of transmission over larger available bandwidths. The use of low resolution data converters is key in reducing the energy requirements of these massive MIMO systems operating over mmWave frequencies. Prior work on downlink transmission for multiuser MIMO using low resolution transceivers focused on evaluating precoding matrices for frequency flat fading [7] and frequency selective channels [8]. The achievable rate, spectral emissions and signal to interference to quantization ratio was evaluated in [9] for the case of 1-bit DACs in downlink massive MIMO. The work in [10] analyzed the impact of 1-bit DACs on maximum

ratio transmission, whereas work in [11] developed a symbol level precoding method for low resolution DACs. Prior work in [12] analytically derived the optimal beamforming and signal transmit matrix by solving the non-convex 1-bit DAC transmission optimization problem. Unfortunately, prior work did not consider multicasting with low-resolution transceivers for mmWave channels.

Through multicasting, the base station (BS) transmits common data to multiple users like network control information etc., which is helpful to make better use of scarce frequency resources and increase the overall system sum rate by reducing redundancy. In this paper, we design the frequency domain beamforming vector for the case of mmWave multicasting with one-bit DACs at the base station. Further, wideband channel is considered for transmission and user devices are assumed to be ideal single antenna transceivers.

Notation: \mathbf{A} (\mathbf{a}) is a matrix representing a quantity in time (frequency) domain; similarly, \mathbf{a} (\mathbf{a}) is a vector; a (\mathbf{a}) is a scalar; $(\cdot)^T$ and $(\cdot)^*$ denote transpose and conjugate transpose; $[\mathbf{A}]_{i,j}$ is the (i,j) -th entry of \mathbf{A} ; $[\mathbf{a}]_j$ represents the j -th element of \mathbf{a} ; \mathbf{I}_N is the $N \times N$ identity matrix; $\mathcal{N}_c(\mathbf{a}, \mathbf{A})$ is a complex Gaussian vector with mean \mathbf{a} and covariance \mathbf{A} ; $\text{sign}(\cdot)$ denote the sign of input; α_R and α_I are the real and imaginary component of complex number α ; $\mathbb{E}[\cdot]$ is the expectation operator; $\|\mathbf{a}\|$ is the norm of vector \mathbf{a} .

II. SYSTEM MODEL

In this paper, we focus on designing the precoding matrix for single-cell multicasting with U active user equipments (UE). The BS operates over a frequency selective channel at mmWave frequencies with a total power budget of P_{tx} . We present the transmitter schematic in Fig. 1 to characterize multicasting with one-bit DACs. As can be seen from this figure, we assume a beamformed MIMO-OFDM system with N subcarriers. The BS uses N_{tot} transmit antennas with each of them having a pair of 1-bit DACs, whereas users have single antennas with infinite resolution transceivers. The BS forms the 1-bit beamforming vectors in the digital frequency domain, which is different from the analog-only and hybrid beamforming based designs for mmWave systems equipped with infinite-resolution DAC. For evaluation of the downlink beamforming vectors, we have assumed that the channel state information (CSI) of all the users is available at the BS. In Section IV, we use numerical simulations to examine the impact of error in CSI estimation on the performance of one-bit multicasting beamforming algorithm.

We now present the generic received signal model for the downlink multicasting. Denote the number of channel taps by

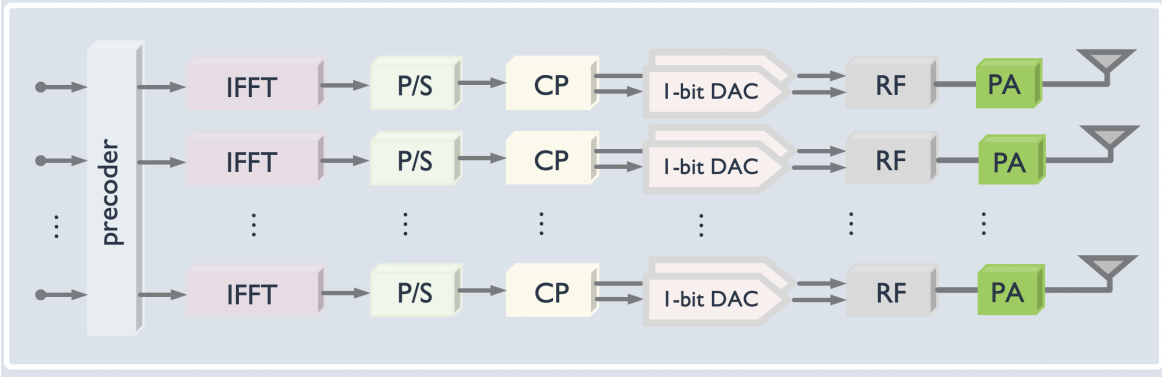

Fig. 1: BS transmitter schematic for multicasting with 1-bit DACs and infinite-resolution ADCs at all active UEs. The BS transmits common data or reference signals to all the active UEs.

L , and the corresponding channel impulse response from the BS to the u -th UE ($u = 1, \dots, U$) at tap $\ell \in \{0, \dots, L-1\}$ by $\mathbf{h}_u[\ell] \in \mathbb{C}^{N_{\text{tot}}}$. The channel taps are assumed to be generated from a geometric channel model with random scattering clusters, typical of mmWave channels. At symbol durations $n = 0, \dots, N-1$, denote the multicast signals transmitted from the BS by $\mathbf{x}[n] \in \mathbb{C}^{N_{\text{tot}}}$, and the additive white Gaussian noise by $w_u[n] \sim \mathcal{N}_c(0, \sigma_w^2)$. We then express the time-domain received signals $y_u[n]$, at symbol durations $n = 0, \dots, N-1$ as

$$y_u[n] = \sum_{\ell=0}^{L-1} \mathbf{h}_u[\ell]^T \mathbf{x}[n-\ell] + w_u[n]. \quad (1)$$

Note that $\mathbf{x}[n]$ embeds both the actual multicast information symbol and the beamforming vector. Denote the frequency-domain counterparts of y_u , \mathbf{h}_u , \mathbf{x} and w_u by y_u , \mathbf{h}_u , \mathbf{x} and w_u , we then express the frequency-domain received signals $y_u[k]$, on subcarriers $k = 0, \dots, N-1$ as

$$y_u[k] = \mathbf{h}_u^T[k] \mathbf{x}[k] + w_u[k]. \quad (2)$$

Denote the multicast beamforming vector from BS on subcarrier k by $\mathbf{p}[k] \in \mathbb{C}^{N_{\text{tot}}}$ and the actual multicast information symbol by $\mathbf{s}[k]$ which is selected from the set of constellation points. To reveal the beamforming effect in $\mathbf{x}[n]$, we first define

$$\mathbf{z}[n] = \frac{1}{N} \sum_{k=0}^{N-1} \mathbf{p}[k] \mathbf{s}[k] \exp\left\{\frac{jk2\pi n}{N}\right\}, \quad n = 0, \dots, N-1.$$

The transmit multicast signal $\mathbf{x}[n]$ is quantized version of $\mathbf{z}[n]$. In general, $\mathbf{x}[n] = \mathcal{Q}_{\text{DAC}}(\mathbf{z}[n])$. For the pertinent case of one-bit DAC, the quantization output would be

$$\mathbf{x}[n] = \sqrt{\frac{P_{\text{tx}}}{2N_{\text{tot}}}} (\text{sign}(z_R[n]) + \text{sign}(z_I[n])) \quad (3)$$

For the case of independent and identically distributed (IID) Gaussian input to the quantizer i.e. assuming $\mathbf{s} \sim \mathcal{N}_c(0, I_U)$, the quantization output can be decoupled into a scaled version of input and uncorrelated distortion component using Bussgang's theorem [7]. However inherent assumption of gaussian signalling in Bussgang's theorem, make its use inappropriate for one-bit DACs. Without decomposition of

quantized signal, it is impossible to theoretically define the SQNR for transmission with one-bit DACs. To overcome this limitation, we define the quantized precoding problem from the perspective of minimizing the symbol error at all the users in the next section.

III. BEAMFORMING VECTOR DESIGN

In one-to-one transmission systems, the aim is to maximize the total sum rate by mitigating interference to different users, contrary to that in multicast, the objective is to maximize the minimum sum rate as there is no interference. In multicast, the transmitter have to ensure that each user is successfully able to decode the transmitted symbol, otherwise the symbol have to be transmitted again. Keeping this in mind, in this section, we describe the design of beamforming vector for the multicast data channel assuming one-bit DAC quantization at the BS. The goal is to minimize the maximum mean square error (MSE) between transmitted symbol vector and received signals at all of the users.

For the case of MIMO-OFDM, the u^{th} receiver estimates the transmitted symbol ($\hat{\mathbf{s}}_u[k]$) after rescaling the received symbol $y_u[k]$ (c.f. (2)) by channel gain factor λ_u as follows:

$$\hat{\mathbf{s}}_u[k] = \lambda_u \cdot y_u[k]. \quad (4)$$

The corresponding linear quantized precoding problem to minimize the mean square error at each user for the k^{th} subcarrier becomes

$$\underset{\{\mathbf{p}[k] \in \mathbb{C}^{N_{\text{tot}}}\}}{\text{minimize}} \max_{\forall u} \{E_{\mathbf{s}}[\|\mathbf{s} - \hat{\mathbf{s}}_u\|^2]\} \quad (5)$$

$$\text{s.t. } E_{\mathbf{s}}[\|\mathbf{x}[n]\|^2] \leq P_{\text{tx}}. \quad (6)$$

In traditional quantized precoding problems the objective is just to minimize the MSE [7], whereas for multicasting the successful transmission is characterized by correct symbol detection at each user. Hence objective in 5 is to minimize the maximum symbol error among all the users, equivalently this implies maximizing the minimum SQNR among all the users. Closed form solution of 5 is challenging due to two reasons, first multicast optimization problems are NP-hard in general [1] and the non-linearity introduced by the DAC quantization function $\mathcal{Q}_{\text{DAC}}(\cdot)$.

To overcome the second challenge, we invoke an important observation from [7] that precoders designed using statistical approximations of quantization function and designed precoders assuming infinite-resolution DACs and then quantizing them, give very similar error-rate performance. NP-hardness of multicasting makes the calculation of optimal solution inefficient, however [2] proved that the asymptotic optimal beamformer is a linear combination of individual channel between users and the BS. Even if global optimal solution is determined, the time complexity of its calculation may be high, which limits its utility to real-time systems. With these motivations, we present our heuristic beamforming design in algorithm 1.

The success of a multicast system depends upon the successful detection of transmitted signal at all the user devices, therefore the presented beamformer attempts to equalize the channel among all the users. The beamforming vector is calculated by adding all the channel coefficients scaled by inverse of channel gains, hence the algorithm is called channel inverse beamforming (CIB). The other intuitive explanation is from the standard multipath model typically used for mmWave MIMO channels, where different path clusters can lead to multiple received signals with different direction of arrival (DoA) [13]. The CIB method captures the main signal direction of each user and then transmits in all those directions with power weightage inversely proportional to channel gain of that user. Next, power is allocated to each SC by waterfilling method as per the accumulated channel gains and the time-domain multicast signal is calculated by IFFT operation. The time complexity scales linearly with both number of users and number of SCs.

Algorithm 1 Channel Inverse Beamforming (CIB) method

- 1: Given: $\mathbf{h}_u[k]$, frequency domain channel response of each user at SC ‘ k ’
 - 2: **for** each SC $n = \{1, 2, \dots, N\}$ **do**
 - 3: | for each user: evaluate $\beta_{u,k} = \frac{1}{\|\mathbf{h}_u[k]\|}$
 - 4: | $\mathbf{p}[k] = \frac{\sum_{u=1}^U \beta_{u,k} \mathbf{h}_u^*[k]}{\sum_{u=1}^U \beta_{u,k}}$
 - 5: | $\zeta[k] = \|\sum_{u=1}^U \beta_{u,k} \mathbf{h}_u[k]\|$
 - 6: **end for**
 - 7: Allocate power $P_{\text{tx}}[k]$ to SC ‘ k ’ using waterfilling, with the channel gains $\zeta[k]$
 - 8: Generate symbols $\mathbf{s}[k]$ for each SC
 - 9: $\mathbf{x}[n] = \text{IFFT}(P_{\text{tx}}[k] \mathbf{p}[k] \mathbf{s}[k])$
-

IV. NUMERICAL SIMULATIONS

For numerical simulations, we consider a mmWave multicast scenario operating at 28 GHz. Users are uniformly distributed in a circle of radius 100 m and UEs are at a height of 1.5 m, whereas the BS height is 25 m. For channel generation we use Quadriga channel simulator [14] with urban micro-cellular (UMi) scenario for non line of sight (NLoS) components. We consider channel bandwidth of 100 MHz. For the wideband channel, the delay spread is found to be less than 640 ns for 95% of time, which corresponds to $L = 64$ channel

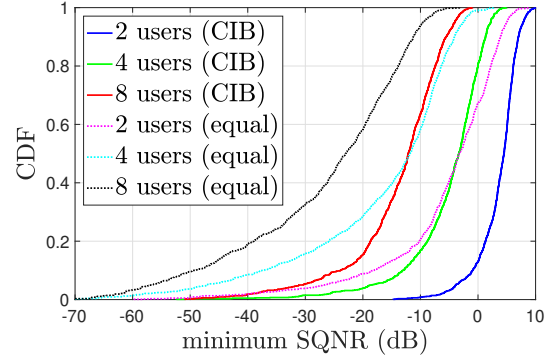

Fig. 2: Empirical CDF of minimum SQNR among different users for the proposed CIB and equal combining beamforming method. The performance decreases as more users are added to the system.

aps. To generate OFDM symbols we used a 256 point DFT and all the numerical results are averaged over 1000 different channel realizations. The BS transmit power is fixed at 25 W. The information symbols $\mathbf{s}[k]$ are generated from a QPSK constellation, which results in a simple decoder at receivers; by just checking the sign of received symbols.

To compare the performance of proposed beamforming approach we use equal combining as the bench mark. In equal combining, the beamforming vector is average of all the users channels from the BS. We evaluated the performance of proposed beamforming method for two different scenarios. First, we varied the number of users in a cell keeping all other parameters same, for the second case we varied the number of antennas at the base station. For the first case, the BS is equipped with $N_{\text{tot}} = 16$ antennas arranged as a uniform linear array with half-wavelength spacing. Fig. 2 shows the cumulative density function (CDF) of the minimum SQNR among all U users. To calculate SQNR of a particular user we first numerically evaluate the uncoded bit error rate (BER) and then estimate SQNR assuming nearest-neighbor decoding for each symbol. Hence for QPSK symbols,

$$\text{SQNR} = (Q^{-1}(\text{BER}))^2, \quad (7)$$

where $Q^{-1}(\cdot)$ is the inverse to the Q -function defined as $Q(x) = \frac{1}{\sqrt{2\pi}} \int_x^\infty \exp(-\frac{\kappa^2}{2}) d\kappa$.

We observe that SQNR deteriorates with increase in number of users. There is an SQNR loss of 8.70 dB as the number of users are doubled for the CIB method, whereas an average loss of 10.5 dB for the equal combining case. The reason for decrease in SQNR is because the beamforming vector is a linear combination of each users channel’s coefficients, and hence not able to effectively compensate for the channel variations of each user with increasing number of users. Table I list the average SQNR values for both CIB and equal combining methods for different users. The proposed beamforming approach provides 11.18 dB average gain in SQNR as compared to the equal combining case and the gain increases as the number of users increase.

Fig. 3 shows the CDF of minimum SQNR as the number of antennas (N_{tot}) is increased for 4 users. Table II list the average SQNR values for both CIB and equal combining

Number of users	CIB	Equal	Gain
2	3.59	-5.57	9.16
4	-5.10	-16.70	11.6
8	-13.81	-26.60	12.79

TABLE I: Expected SQNR values for the channel inverse beamforming and equal combining as the number of users in a particular cells increase. The average gain is 11.18 dB.

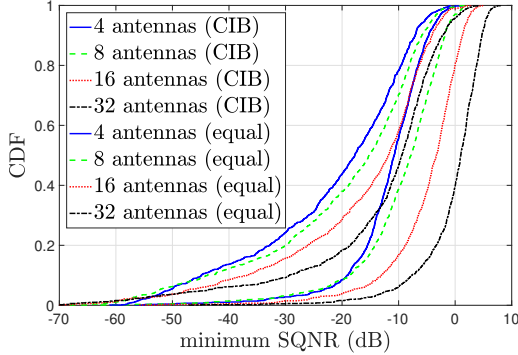

Fig. 3: Empirical CDF of minimum SQNR among 4 users for the proposed CIB and equal combining beamforming vector as the number of transmit antennas is increased. The performance improves as more antennas area added to the BS.

methods for different number of BS antennas. It can be observed that the average SQNR increases as the number of antennas is increased for a fixed transmit power, which is as per the intuition that more antennas provide more degrees of freedom. For this case as well, the proposed beamforming method provides around 11.08 dB gain in SQNR. Further, the amount of increase of SQNR for CIB is higher as more antennas are added at the BS. This shows that CIB scales more efficiently to the increase in BS antennas and number of users as compared to the equal combining approach.

BS antennas	CIB	Equal	Gain
4	-11.82	-21.58	9.76
8	-9.69	-19.88	10.19
16	-5.10	-16.68	11.58
32	-0.44	-13.23	12.8

TABLE II: Expected SQNR values for the channel inverse beamforming and equal combining as the number of BS antennas is increased. The average gain is 11.08 dB.

Till now, we have assumed that the BS have access to full CSI. However, the analog and digital converter (ADC) at BS could also be of finite resolution and this will introduce some error in the CSI estimation. For this set of simulation, we assume that BS is only able to estimate a noisy version of $\mathbf{h}_u[k]$. For a given CSI estimation error $\epsilon \in [0, 1]$ and distortion noise $\mathbb{N}_{\mathbf{h}_u[k]} \sim \mathcal{N}_c(0, \mathbf{I}_{N_{tot}})$, the estimated channel coefficients ($\tilde{\mathbf{h}}_u[k]$) are approximated as follows,

$$\tilde{\mathbf{h}}_u[k] = (\sqrt{1 - \epsilon}) \cdot \mathbf{h}_u[k] + \|\mathbf{h}_u[k]\| \sqrt{\epsilon} \cdot \mathbb{N}_{\mathbf{h}_u[k]}. \quad (8)$$

Increase in ϵ values corresponds to higher error in channel estimation; $\epsilon = 0$ corresponds to perfect CSI whereas $\epsilon = 1$ corresponds to no CSI. Fig. 4 shows the minimum SQNR among all the users as the CSI estimation error is increased

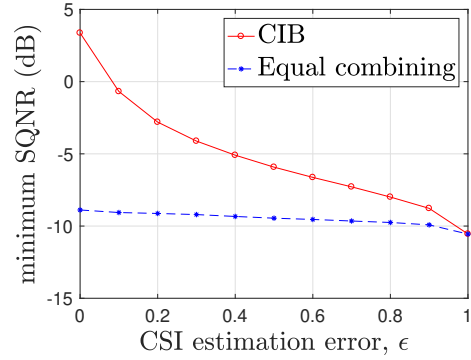

Fig. 4: SQNR variation as the channel estimation error increases for 4 users and 64 BS antennas. The minimum SQNR decreases as error in CSI estimation increases.

for a system with 4 users and 64 BS antennas. The error in CSI reduces the system performance, however the proposed CIB method outperforms equal combining whenever $\epsilon \neq 1$.

V. CONCLUSIONS

In this paper, we designed a beamforming vector for MIMO-OFDM multicasting with one-bit transceivers. The proposed beamforming vector is inverse power weighted sum of individual channel gains for different subcarriers. Numerical simulation results show that minimum SQNR increases with increase in number of antennas and with decrease in the number of multicast users. Further theoretical analysis of sum rate and error performance of proposed beamforming approach remain as future work.

REFERENCES

- [1] N. D. Sidiropoulos, T. N. Davidson, and Zhi-Quan Luo, "Transmit beamforming for physical-layer multicasting," *IEEE Trans. Signal Process.*, vol. 54, no. 6, pp. 2239–2251, Jun. 2006.
- [2] Z. Xiang, M. Tao, and X. Wang, "Massive MIMO multicasting in noncooperative cellular networks," *IEEE J. Sel. Areas Commun.*, vol. 32, no. 6, pp. 1180–1193, Jun. 2014.
- [3] N. Jindal and Z. Luo, "Capacity limits of multiple antenna multicast," in *Proc. IEEE ISIT*, Seattle, WA, USA, Jul. 2006, pp. 1841–1845.
- [4] S. Y. Park, D. J. Love, and D. H. Kim, "Capacity limits of multi-antenna multicasting under correlated fading channels," *IEEE Trans. Commun.*, vol. 58, no. 7, pp. 2002–2013, Jul. 2010.
- [5] J. Wang, S. Y. Park, D. J. Love, and M. D. Zoltowski, "Throughput delay tradeoff for wireless multicast using hybrid-ARQ protocols," *IEEE Trans. Commun.*, vol. 58, no. 9, pp. 2741–2751, Aug. 2010.
- [6] J. Joung, H. D. Nguyen, P. H. Tan, and S. Sun, "Multicast linear precoding for MIMO-OFDM systems," *IEEE Commun. Lett.*, vol. 19, no. 6, pp. 993–996, Jun. 2015.
- [7] S. Jacobsson, G. Durisi, M. Coldrey, T. Goldstein, and C. Studer, "Quantized precoding for massive MU-MIMO," *IEEE Trans. Commun.*, vol. 65, no. 11, pp. 4670–4684, Nov. 2017.
- [8] S. Jacobsson, G. Durisi, M. Coldrey, and C. Studer, "Linear precoding with low-resolution DACs for massive MU-MIMO-OFDM downlink," *IEEE Trans. Wireless Commun.*, vol. 18, no. 3, pp. 1595–1609, Mar. 2019.
- [9] A. K. Saxena, A. Mezghani, R. Bendlin, S. Nammi, R. W. Heath Jr., J. G. Andrews, and A. Chopra, "Asymptotic performance of downlink massive MIMO with 1-bit quantized zero-forcing precoding," in *Proc. IEEE 20th Int. Workshop Signal Process. Adv. Wireless Commun. (SPAWC)*, Jul. 2019, pp. 1–5.
- [10] J. Guerreiro, R. Dinis, and P. Montezuma, "Use of 1-bit digital-to-analogue converters in massive MIMO systems," *IEEE Electron. Lett.*, vol. 52, no. 9, pp. 778–779, Apr. 2016.

- [11] C. G. Tsinos, A. Kalantari, S. Chatzinotas, and B. Ottersten, "Symbol-level precoding with low resolution DACs for large-scale array MU-MIMO systems," in *Proc. IEEE 19th Int. Workshop Signal Process. Adv. Wireless Commun. (SPAWC)*, Jun. 2018, pp. 1–5.
- [12] A. Li, C. Masouros, F. Liu, and A. L. Swindlehurst, "Massive MIMO 1-bit DAC transmission: A low-complexity symbol scaling approach," *IEEE Trans. Wireless Commun.*, vol. 17, no. 11, pp. 7559–7575, Nov. 2018.
- [13] R. W. Heath Jr., N. González-Prelcic, S. Rangan, W. Roh, and A. M. Sayeed, "An overview of signal processing techniques for millimeter wave mimo systems," *IEEE J. Sel. Topics Signal Process.*, vol. 10, no. 3, pp. 436–453, Apr. 2016.
- [14] S. Jaeckel, L. Raschkowski, K. Börner, and L. Thiele, "QuaDRiGa: A 3-D multi-cell channel model with time evolution for enabling virtual field trials," *IEEE Trans. Antennas Propag.*, vol. 62, no. 6, pp. 3242–3256, Jun. 2014.